

# Dry Vacuum Pump mXDS3 Scroll Pump

## INSTRUCTION MANUAL

edwardsvacuum.com



DESCRIPTION	ITEM NUMBER	DESCRIPTION	ITEM NUMBER
mXDS3 230V 1ph 50/60 Hz	A74401903	mXDS3s 230V 1ph 50/60 Hz	A74402903
mXDS3 200V 1ph 50/60 Hz	A74401904	mXDS3s 200V 1ph 50/60 Hz	A74402904
mXDS3 115V 1ph 50/60 Hz	A74401906	mXDS3s 115V 1ph 50/60 Hz	A74402906
mXDS3 100V 1ph 50/60 Hz	A74401907	mXDS3s 100V 1ph 50/60 Hz	A74402907

## Copyright notice

©Edwards Limited 2023. All rights reserved.

Published: 7/28/2023

## Associated publications

<b>Publication title</b>	<b>Publication number</b>
Vacuum Pump and Vacuum System Safety	P40040100

## Trademark credit

Edwards and the Edwards logo are trademarks of Edwards Limited, Innovation Drive, Burgess Hill, West Sussex RH15 9TW.

## Disclaimer

The content of this manual may change from time to time without notice. We accept no liability for any errors that may appear in this manual nor do we make any expressed or implied warranties regarding the content. As far as practical we have ensured that the products have been designed and constructed to be safe and without risks when properly installed and used in accordance with their operating instructions.

We accept no liability for loss of profit, loss of market or any other indirect or consequential loss whatsoever.

Product warranty and limit of liability are dealt with in our standard terms and conditions of sale or negotiated contract under which this document is supplied.

You must use this product as described in this manual. Read the manual before you install, operate, or maintain the product.

# Contents

<b>1. Safety and compliance.</b> . . . . .	<b>7</b>
1.1 Definition of Warnings and Cautions. . . . .	7
1.2 Trained personnel . . . . .	7
1.3 Safety symbols. . . . .	8
<b>2. Introduction.</b> . . . . .	<b>9</b>
2.1 Scope of this manual. . . . .	9
2.2 ATEX directive implication. . . . .	9
2.3 Description. . . . .	10
2.4 Intended use. . . . .	12
2.4.1 Flammable materials. . . . .	12
2.4.2 Pumped media. . . . .	12
2.5 Misuse. . . . .	13
<b>3. Technical data.</b> . . . . .	<b>14</b>
3.1 Operating and storage conditions. . . . .	14
3.2 Performance. . . . .	14
3.2.1 Performance data. . . . .	14
3.2.2 Performance characteristics. . . . .	15
3.3 Mechanical data. . . . .	16
3.3.1 General mechanical data. . . . .	16
3.3.2 Pump cover. . . . .	17
3.3.3 Sound and vibration data. . . . .	17
3.3.4 Maximum surface temperature. . . . .	17
3.3.5 Materials of construction. . . . .	17
3.4 Electrical data. . . . .	18
3.4.1 Electrical cables. . . . .	18
<b>4. Installation.</b> . . . . .	<b>20</b>
4.1 Installation safety. . . . .	20
4.2 System design considerations. . . . .	20
4.3 Unpack and inspect. . . . .	21
4.4 Position the pump. . . . .	22
4.4.1 Mechanical fixing. . . . .	22
4.5 Connect to the vacuum system. . . . .	22
4.6 Electrical installation. . . . .	23
4.6.1 Fuses and circuit breakers. . . . .	23
4.6.2 Electrical supply connection. . . . .	24
4.6.3 Disconnect the pump from the electrical supply. . . . .	24
4.6.4 Connect the pump to the electrical supply. . . . .	24

<b>5. Operation</b>	<b>25</b>
5.1 Manual operation	25
5.1.1 Start and stop	25
5.2 Gas ballast control	26
5.2.1 Use of gas ballast control	26
5.2.2 Gas ballast control plug	26
5.3 Start-up procedure	27
5.4 To achieve ultimate vacuum	28
5.5 To pump condensable vapours	28
5.6 Shut down	28
<b>6. Maintenance</b>	<b>29</b>
6.1 Maintenance safety	29
6.2 Maintenance plan	30
6.3 Inspect and clean the inlet strainer	30
6.4 Clean the external fan cover	30
6.5 Check the pump performance	31
6.6 Replace the tip-seals	31
6.7 Replace the pump bearings	31
6.8 Electrical safety check	32
<b>7. Fault finding</b>	<b>33</b>
7.1 The pump has failed to start or has stopped	33
7.2 The pump has failed to achieve the required performance	33
7.3 The pump has poor ultimate vacuum	33
7.4 The pump is noisy	34
7.5 The pump surface temperature is high	35
<b>8. Storage</b>	<b>36</b>
8.1 Pump storage for less than 2 years	36
8.2 Pump storage for more than 2 years	36
<b>9. Disposal</b>	<b>37</b>
<b>10. Spares and accessories</b>	<b>38</b>
10.1 Spares	38
10.1.1 Tip-seal kit	38
10.1.2 Bearing replacement kit	38
10.1.3 Gas ballast and exhaust kit	38
10.1.4 DN 16 ISO KF inlet adaptor	38
10.2 Accessories	39
10.2.1 Inlet valve	40
10.2.2 Delay relay	42
10.2.3 Gas ballast or exhaust push-in fitting	43

10.2.4 Gas ballast fine restrictor.....	44
10.2.5 Inlet push in fitting 1/4".....	45
10.2.6 Inlet 1/4" BSP adaptor.....	46
10.2.7 Base mounting plate.....	46
10.2.8 Bracket.....	46
10.2.9 Exhaust silencer/gas ballast filter.....	47
10.2.10 Vibration isolator kit.....	47
10.2.11 Inlet filter.....	47
10.2.12 Reduction DN 16/25 ISO-KF.....	48
10.2.13 Adhesive rubber pads.....	48
10.2.14 Electrical cables.....	48
<b>11. Service.....</b>	<b>49</b>
11.1 Return the equipment or components for service.....	49
<b>12. Legal declarations.....</b>	<b>50</b>

# List of Figures

Figure 1: mXDS3 scroll pump. . . . .	11
Figure 2: mXDS3s scroll pump. . . . .	11
Figure 3: Performance characteristics at 50Hz. . . . .	16
Figure 4: Performance characteristics at 60Hz. . . . .	16
Figure 5: Installation drawing. . . . .	21
Figure 6: User interface panel. . . . .	25
Figure 7: Opening gas ballast plug. . . . .	27
Figure 8: Gas ballast plug removed. . . . .	27
Figure 9: Poor ultimate vacuum flow chart with inlet sealed. . . . .	34
Figure 10: Anti-rotation device. . . . .	34
Figure 11: Noisy pump flow chart with inlet sealed. . . . .	35
Figure 12: The mXDS3/mXDS3s accessories. . . . .	39
Figure 13: Inlet valve. . . . .	41
Figure 14: Replace capacitor. . . . .	43
Figure 15: Pin connection of delay relay. . . . .	43
Figure 16: mXDS3 mounting. . . . .	47

# 1. Safety and compliance

For safe operation from the start, read these instructions carefully before you install or commission the equipment and keep them safe for future use. Read all the safety instructions in this section and the rest of this manual carefully and make sure that you obey these instructions.

The instruction manual is an important safety document that we often deliver digitally. It is your responsibility to keep the instruction manual available and visible while working with the equipment. Please download the digital version of the instruction manual for use on your device or print it if a device will not be available.

## 1.1 Definition of Warnings and Cautions

Important safety information is highlighted as warning and caution instructions which are defined as follows. Different symbols are used according to the type of hazard.

### **WARNING:**

**If you do not obey a warning, there is a risk of injury or death.**

### **CAUTION:**

**If you do not obey a caution, there is a risk of minor injury, damage to equipment, related equipment or process.**

### **NOTICE:**

**Information about properties or instructions for an action which, if ignored, will cause damage to the equipment.**

We reserve the right to change the design and the stated data. The illustrations are not binding.

## 1.2 Trained personnel







For the operation of this equipment “trained personnel” are:

- skilled workers with knowledge in the fields of mechanics, electrical engineering, pollution abatement and vacuum technology and
- personnel specially trained for the operation of vacuum pumps

## 1.3 Safety symbols

The safety symbols on the products show the areas where care and attention is necessary.

The safety symbols that we use on the product or in the product documentation have the following meanings:

	<p><b>Warning/Caution</b> Risk of injury and/or damage to equipment. An appropriate safety instruction must be followed or a potential hazard exists.</p>
	<p><b>Warning - Dangerous voltage</b> Risk of injury. Identifies possible sources of hazardous electrical shock.</p>
	<p><b>Warning - Hot surfaces</b> Risk of injury. Identifies a surface capable of inflicting burns through contact.</p>
	<p><b>Warning - Risk of explosion</b> Risk of injury or damage to equipment. Identifies a situation that could result in an explosion.</p>
	<p><b>Mandatory action symbol</b> Failure to comply with this action may result in injury or damage to equipment.</p>
	<p><b>Mandatory - Read the manual</b> Failure to comply with this action may result in injury or damage to equipment.</p>



## 2. Introduction

### 2.1 Scope of this manual

This manual provides installation, operation and maintenance instructions for the mXDS3/mXDS3s series of scroll pump. The pump must be used as specified in this manual or the protection provided by the equipment may be impaired. Read this manual before installing and operating the pump.

### 2.2 ATEX directive implication



This equipment is designed to meet the requirements of Group II Category 3G in respects to ignition sources internal to the pump. This classification is in accordance with Directive 2014/34/EU.

The pumping mechanism and its mechanical components exposed to the "INTERNAL ATMOSPHERES" within the pump system is defined as: equipment group II, equipment category 3 - in accordance with the ATEX directive. This designation ONLY applies to the mechanical pumping mechanism, which is sealed from the external pump system and its operating environment. An ATEX category has not been assigned in respect of potential ignition sources on the outside of the equipment as the equipment has not been designed for use where there is an external potentially explosive atmosphere.

There is no potential source of ignition within the pump during normal operation but there may be potential sources of ignition under conditions of rare or unexpected malfunction as defined in the directive. As a result of this, it is necessary to consider the potential consequences of ignition sources occurring under rare or expected malfunction. (Refer ATEX137 1992/92/EC).

The notations used in these ratings are as follows:

	Equipment to be used in a potentially explosive atmosphere
II	Equipment group II - non mining equipment as defined in directive 2014/34/EU
3	Equipment category - suitable for hazardous area zone 2 as defined in directive 2014/34/EU
G	Explosive atmosphere caused by gases, vapours or mists

Ex h	Non-electrical equipment for explosive atmospheres, regardless of which type of protection is used; see EN ISO 80079-37. Non-electrical equipment for explosive atmospheres
IIC	Suitable for flammable gas group IIC - (also Hydrogen, Acetylene, Carbon disulphide)
T4	Temperature class - <135 °C
GC	Equipment protection level (EPL) as defined in EN ISO 80079-36
X	Specific conditions of use of the equipment. The special conditions and notes provided in the Operating Instructions will be applicable.

When flammable materials are present within the equipment you must:

- Not allow air to enter the equipment.
- Ensure the system is leak tight.
- Use an inert gas purge (for example, nitrogen) to dilute any flammable gasses or vapours entering the pump inlet, and use an inert gas purge to reduce the concentration of flammable gases or vapours in the pump and in the exhaust pipeline, to less than one quarter of the gases published Lower Explosion Limits (LEL).
- If higher concentrations of flammable gases or vapours is requested, contact us for support.

Do not pump pyrophoric materials, process debris could produce an ignition source on the scroll surface.

Do not locate the pump in an ATEX zoned area, the ATEX specification is not applicable for external atmospheres.

When planning to pump hazardous substances with this pump, read the related chapters in the Safety Booklet and in these Operating Instructions first.

Further details can be obtained by contacting us.

## 2.3 Description

The pump is shown in [Figure: mXDS3/mXDS3s scroll pump](#) on page 11.

The pump is a dry vacuum pump as all the bearings, with their hydrocarbon lubricant, are isolated from the vacuum space. The pump is suitable for use on vapour handling processes and may be used for some pumping applications. For information on pumping flammable gases, contact us.

The body of the pump includes a fixed scroll and an orbiting scroll. The orbiting scroll is controlled by an electric motor through an eccentric cam on the motor drive shaft. The movement of the orbiting scroll, meshed with the fixed scroll, forms successive crescent shaped volumes in the pump. Gas that enters the pump through the inlet is compressed by the movement of the orbiting scroll and swept towards the centre of the fixed scroll. The compressed gas enters the exhaust port near the centre of the fixed scroll and is exhausted from the pump through the outlet.

The pump is supplied with factory fitted inlet isolation valve and delay opening relay. Refer to [Operating and storage conditions](#) on page 14 for details of operating conditions.

**Figure 1** mXDS3 scroll pump

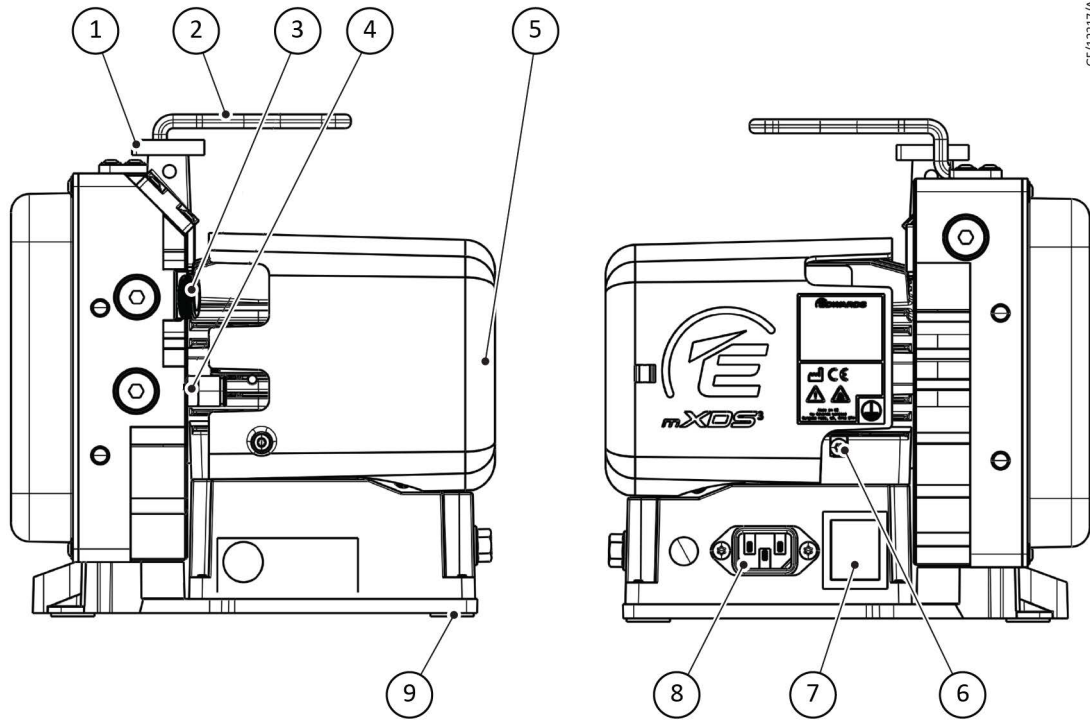

GE/12217/A

- 1. DN 16 ISO-KF inlet port
- 3. Gas ballast control
- 5. Cooling fan
- 7. On/OFF switch
- 9. Adhesive rubber pads

- 2. Handle
- 4. 1/8" BSP Exhaust port
- 6. Secondary earth bond point
- 8. Mains power connector

**Figure 2** mXDS3s scroll pump

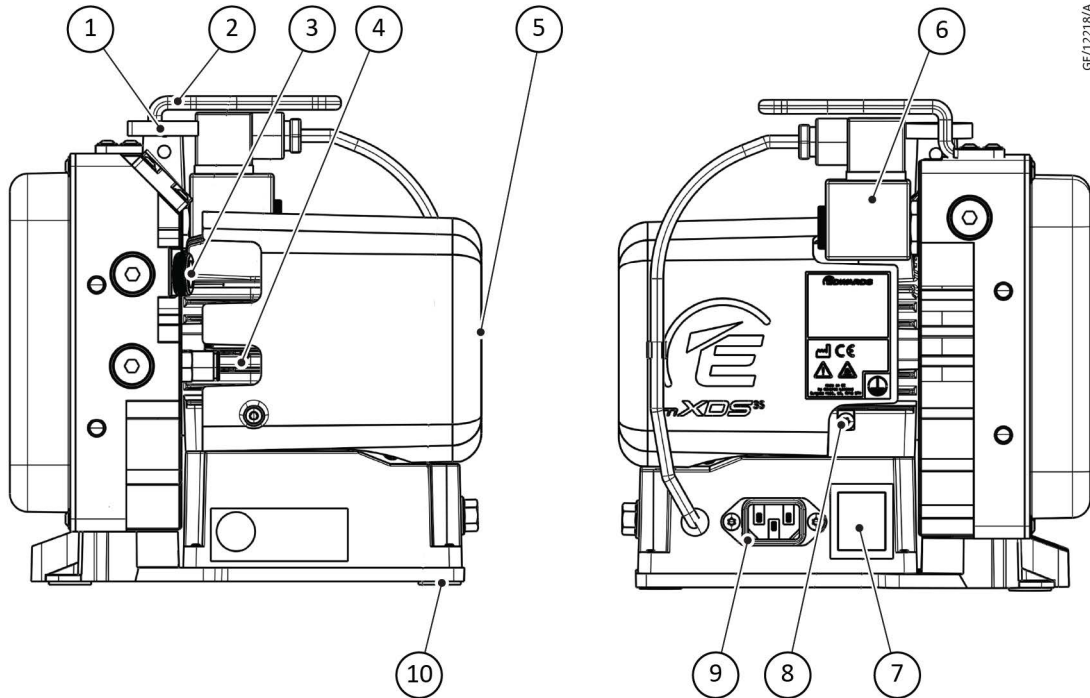

GE/12218/A

- 1. DN 16 ISO-KF inlet port
- 3. Gas ballast control
- 5. Cooling fan
- 7. On/OFF switch
- 9. Mains power connector

- 2. Handle
- 4. 1/8" BSP Exhaust port
- 6. Inlet isolation valve
- 8. Secondary earth bond point
- 10. Adhesive rubber pads

## 2.4 Intended use

Manipulation is allowed only when the pump is switched off.

The Intended uses of the pump are:

Application	
<b>Instrumentation</b>	
Analytical instruments	✓
Laboratory bench top vacuum	✓
Electron microscopy/spectroscopy	✓
<b>General</b>	
Helium leak detectors	✓
Research and development	✓
Turbomolecular backing pumps	✓

### 2.4.1 Flammable materials



#### **WARNING: FLAMMABLE MATERIALS**

**Risk of injury or damage to the equipment. Obey the safety instructions and make note of precautions to make sure that the pumped gases do not enter their flammable ranges.**

When flammable materials are present within the equipment:

- Do not allow air to enter the equipment.
- Make sure the system is leak tight.
- Use an inert gas purge (for example, nitrogen purge) to dilute any flammable gasses or vapours entering the pump inlet and use an inert gas purge to reduce the concentration of flammable gases or vapours in the pump and in the exhaust pipeline, to less than one quarter of the gases published Lower Explosion Limits (LEL).
- Use an inert gas purge into the pump gas ballast connection to prevent the condensation of flammable vapours within the pump mechanism and exhaust pipeline.

### 2.4.2 Pumped media



#### **WARNING: EXPLOSIVE GASES**

**Risk of injury. Do not use the pump to pump flammable, pyrophoric materials or dust.**

The pump is designed to pump the following gases:

- Air
- Carbon dioxide
- Helium

- Nitrogen
- Inert gases including Neon and Argon
- Oxygen (O<sub>2</sub>) up to 21%

For all other gases and oxidants please contact us.

The pump can be used to pump water vapour. Caution must be taken to make sure that vapour does not condense inside the pump. Refer to [Gas ballast control](#) on page 26 on how to prevent condensation of water vapour in the pump. Make sure the pump is allowed to get to normal operating temperature (1 hour) before flowing any gas/vapour and make sure that the pump is suitably purged before it is turned off to avoid accumulation of pumped gas or vapours within the mechanism.

Pumping water vapour reduces the tip seal life time. Water vapour handling capacity is up to 20g/h.

If pumping a vapour or gas not in the list above or if the temperature is higher than 40 °C, contact us for advice.

## 2.5 Misuse

If you do not use the equipment for an intended use, then you might invalidate your warranty and become responsible for any resulting safety implications.

Do not use the pumps to pump hazardous substances.

### 3. Technical data



#### **WARNING: HOT SURFACE**

Risk of injury or damage to the equipment. If the pump is operated outside the specified limits, the pump housing may become hot.

### 3.1 Operating and storage conditions

*Table 1 Operating and storage conditions*

Parameter	Value
Ambient temperature range (storage)	- 30 °C to + 70 °C
Ambient temperature range (operation)	+ 5 °C to + 40 °C
Maximum humidity (storage in original packaging)	95% RH
Maximum humidity (operation)	90% RH

If the storage time is less than 2 years start the pump by instruction described in [Pump storage for less than 2 years](#).

If the storage time is more than 2 years continue by instruction described in [Pump storage for more than 2 years](#) on page 36.

*Table 2 Environmental conditions*

Parameter	Value
Pollution	Pollution degree 2
Installation	Installation category II
Altitude restriction	Maximum 2000 m*
Area of use	Indoor

\* The product can be used up to an altitude of 3000 m. However, the product is only cTÜVus certified for use up to 2000 m.

### 3.2 Performance

#### 3.2.1 Performance data

*Table 3 Performance data*

Description	mXDS3/mXDS3s at 50 Hz	mXDS3/mXDS3s at 60 Hz
Peak pumping speed (m <sup>3</sup> h <sup>-1</sup> )	3.0	3.5
Maximum permitted at 50/60 Hz inlet pressure (mbar) <sup>*‡</sup>	1000	
Maximum permitted exhaust pressure bar(g) <sup>†</sup>	0.5	

Description	mXDS3/mXDS3s at 50 Hz	mXDS3/mXDS3s at 60 Hz
Maximum permitted gas ballast inlet pressure bar(g)	0.5	
Maximum pressure rise when stopped, with no inlet or gas ballast flow (mbar l within 5 minutes)	15	
Leak tightness (mbar l s <sup>-1</sup> ) air equivalent	< 1 x 10 <sup>-4</sup>	
Maximum inlet peak pressure bar (g) (Unintended exposure) <sup>‡</sup>	1	

\* These pumps are designed to pump down from atmospheric pressure, but prolonged operation at high inlet pressures may reduce bearing life.

† These pumps are intended to exhaust to atmospheric pressure. High exhaust pressure may reduce tip seal life and bearing life.

‡ Large volumes may be pumped, but prolonged operation at high inlet pressures may reduce bearing life and tip seal life.

 **Note:**

*If the pump is operated outside the specified limits, then the pump housing may become hot; and tip seal wear rate will be increased.*

### 3.2.2 Performance characteristics

The position of the gas ballast control defines the performance characteristics of the pump. These performance characteristics are listed in [Table: Performance characteristics](#).

**Table 4 Performance characteristics**

Parameter		Value
Pump ultimate(mbar)	Gas ballast closed	0.1
	Gas ballast plug 1 turn	0.15
	Gas ballast plug removed	0.3
Gas ballast flow (l min <sup>-1</sup> )	Gas ballast plug 1 turn	2.5
	Gas ballast plug removed	4

**Figure 3** Performance characteristics at 50Hz

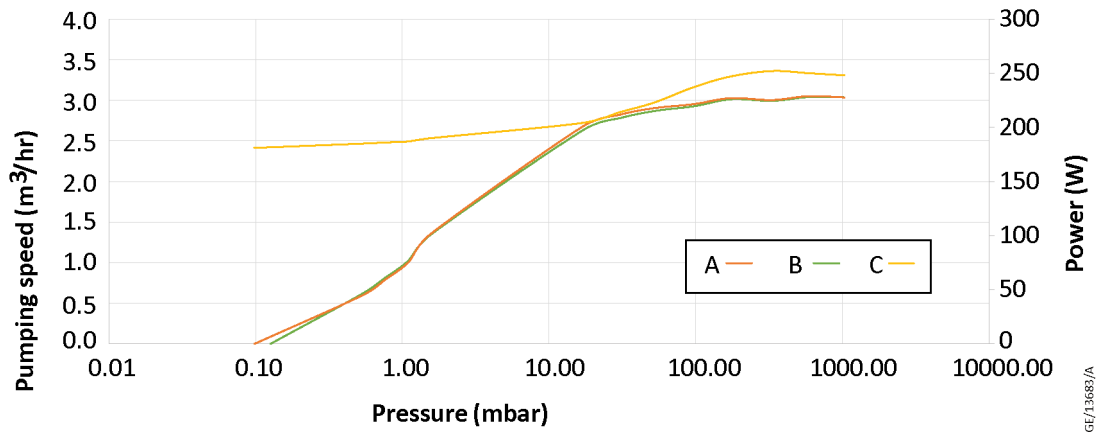

- A. No GB at 50 Hz
- B. With GB at 50 Hz
- C. No GB at 50 Hz Power

**Figure 4** Performance characteristics at 60Hz

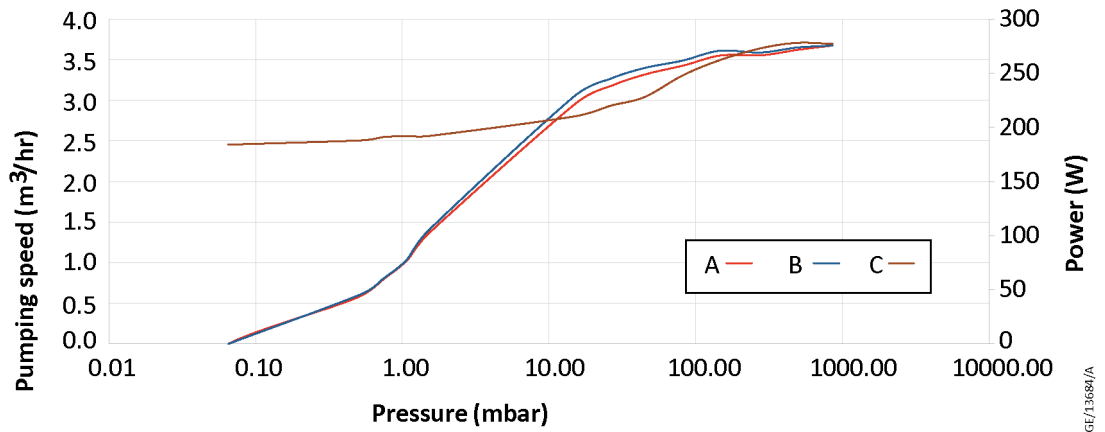

- A. With GB at 60 Hz
- B. No GB at 60 Hz
- C. No GB at 60 Hz Power

### 3.3 Mechanical data

#### 3.3.1 General mechanical data

*Table 5 General mechanical data*

Parameter	Value
Overall dimensions (L x W x H)	224 x 158 x 231 mm
Maximum tilt angle	15 degrees
Nominal rotational speed	3000 RPM @50 Hz/ 3600 RPM @60 Hz
Mass (maximum)	3 - 7.8 kg 3s - 8.0 kg



Parameter	Value
Inlet connection	DN 16 ISO-KF
Outlet connection	1/8" BSP / 6x8 mm Hose

### 3.3.2 Pump cover



#### CAUTION:

As per IEC 61010-1 the cover used on this pump complies to IK 06 which equals 1J impact resistance.

*Table 6 Pump cover*

Parameter	Value
Cover mechanical resistance	IK 06 – 1J

### 3.3.3 Sound and vibration data

*Table 7 Sound and vibration data*

Parameter	Value
Sound pressure, measured at ultimate vacuum 1 meter from the end of the pump to ISO 3744	54.0 dB (A) ± 2.5 Declared dual number noise emission values according with ISO 4871 check
Vibration: measured at the plane of bearings ISO 20816-1	Class 1C < 4.5 mm s <sup>-1</sup> (rms radial)

### 3.3.4 Maximum surface temperature

Maximum surface temperature values at ultimate on inlet at ambient 40° C.

T1 Handle top	T2 Handle bottom	T3 Fix Scroll top	T4 Motor	T5 Front cover	T6 Inlet valve
50.0	55.0	65.0	65.0	65.0	85.0

### 3.3.5 Materials of construction

All surfaces of the pump which are exposed to the pumped gases and vapours are free from copper, zinc and cadmium. Exposed components include: anodised aluminium scrolls, aluminium housing, engineering polymer inlet, stainless steel push-in adaptor, PTFE composite tip-seals, various stainless steel parts, fluoroelastomer seals.

However, the solenoid inlet isolation valve incorporated into the S version of the pump contains brass which is exposed to the pumped gases and vapours. Please read the following statement from our safety manual with regards to Brass / heavy metals and Azides (especially Sodium Azide).

#### Sodium azide

Sodium azide is occasionally used in the preparation of products for freeze drying and in other manufacturing processes. Sodium azide can produce hydrozoic acid. Hydrozoic

acid vapours can react with heavy metals to form unstable metal azides. These azides may explode spontaneously.

The heavy metals include:

Barium	Cadmium	Caesium
Calcium	Copper	Lead
Lithium	Manganese	Potassium
Rubidium	Silver	Sodium
Strontium	Tin	Zinc
Copper and Zinc alloys (such as brass)		

Brass, copper, cadmium, tin and zinc are commonly used in any components in vacuum pumps, accessories and pipes. If your process system uses or produces sodium azide, you must ensure that the gas path in your process system does not contain heavy metals.

Other materials of construction of the pump include steel, copper, hydrocarbon lubricant (exhaust side) and chemically resistant polymers.

### 3.4 Electrical data

*Table 8 Electrical ratings for continuous operation*

Pump	Supply (Vac rms)	Phase	Frequency (Hz)	Running current (A rms @50Hz)	Inrush current (A rms @50Hz)
mXDS3	100 ± 6 %	Single	50 - 60	2.6	9.5
	115 ± 10 %	Single	50 - 60	2.25	10.5
	200 ± 10 %	Single	50 - 60	1.3	4.5
	230 ± 10 %	Single	50 - 60	1.15	5.5
mXDS3s	100 ± 6 %	Single	50 - 60	2.85	9.5
	115 ± 10 %	Single	50 - 60	2.5	10.5
	200 ± 10 %	Single	50 - 60	1.43	4.5
	230 ± 10 %	Single	50 - 60	1.24	5.5

*Table 9 Recommended regional supply protection*

Area	Voltage	Rating
UK	230 V	T2AH250V
Europe	230 V	T2AH250V
US	120 V	T4AH125V
Japan	100 V	T4AH125V

#### 3.4.1 Electrical cables

Recommended cord sets and fuses for regional requirements.

Description	Rating	Coupler type	Item number
Cord set assembly, UK	Cable Style = H05VV-F, 3 x 1.0 mm <sup>2</sup> , 300 V, 70 °C, maximum length of 2.0 metres Plug Type = BS1363 UK plug Appliance Coupler = IEC60320 style C14 Fuse Type = BS1363 10 Amp fuse, to an IEC60320 style	Straight entry	A50505000
Cord set assembly, Europe	Cable Style = H05VV-F, 3 x 1.0 mm <sup>2</sup> , 300 V, 70 °C, maximum length of 2.0 metres Plug Type = European Schuko VDE approved, 16 A 250 V rated with dual earthing contact Appliance Coupler = IEC60320 style C14	Straight entry	A50506000
Cord set assembly, USA/Canada	Cable style = SJT, 3 x 18 AWG, 300 V, 70 °C, VW-1 maximum length of 2.0 metres Plug Type = NEMA, 5-15P plug Appliance Coupler = IEC 60320 style C14	Straight entry	A50507000

## 4. Installation

### 4.1 Installation safety



#### **WARNING: SAFETY INFORMATION**

**Risk of injury or damage to the equipment. Obey the safety instructions in this section and take note of appropriate precautions.**

**Prevent any part of the human body coming into contact with the vacuum.**

**The pump is not intended for pumping explosive gases continuously.**

Make sure that the pump is suitable for the application. If in doubt, refer our guidelines on vacuum pump and vacuum system safety, or contact us for advice.

A suitably trained and supervised technician must perform the installation of the pump. Obey the safety instructions listed below, especially when connecting the pump into an existing system. Details of the specific safety precautions are given at the appropriate point in the instructions.

- Wear the appropriate safety clothing if contact with contaminated components is anticipated. Dismantle and clean contaminated components inside a fume cupboard.
- Before starting any installation work, vent and purge the vacuum system with nitrogen or another inert gas.
- Make sure that the installation technician is familiar with the safety procedures that relate to the products handled by the pumping system.
- Disconnect the other components in the pumping system from the electrical supply to prevent accidental operation.

### 4.2 System design considerations

Consider the following points when designing the pumping system:

We recommend you to use a suitable foreline vacuum isolation valve to allow the pump to warm up whilst isolated before pumping condensable vapours or if a vacuum needs to be maintained when the pump is not running.

Avoid high levels of heat input into the pump from the process gases, otherwise the pump may overheat and cause the thermal protection system to operate.

Make sure that the exhaust pipeline cannot become blocked. If an exhaust isolation valve is installed, make sure that the pump cannot be operated with the valve closed. Refer to [Connect to the vacuum system](#) on page 22.

It is advised to check the main structure frequencies of the device where the pump is installed.

Resonance could occur in case of main frequencies around 50 or 60 Hz.

Provide for a purge of inert gas when the pumping system is shut down, to dilute dangerous gases to safe concentrations. Contact our Application team for further advice on dilution requirements if required.

Figure 5 Installation drawing

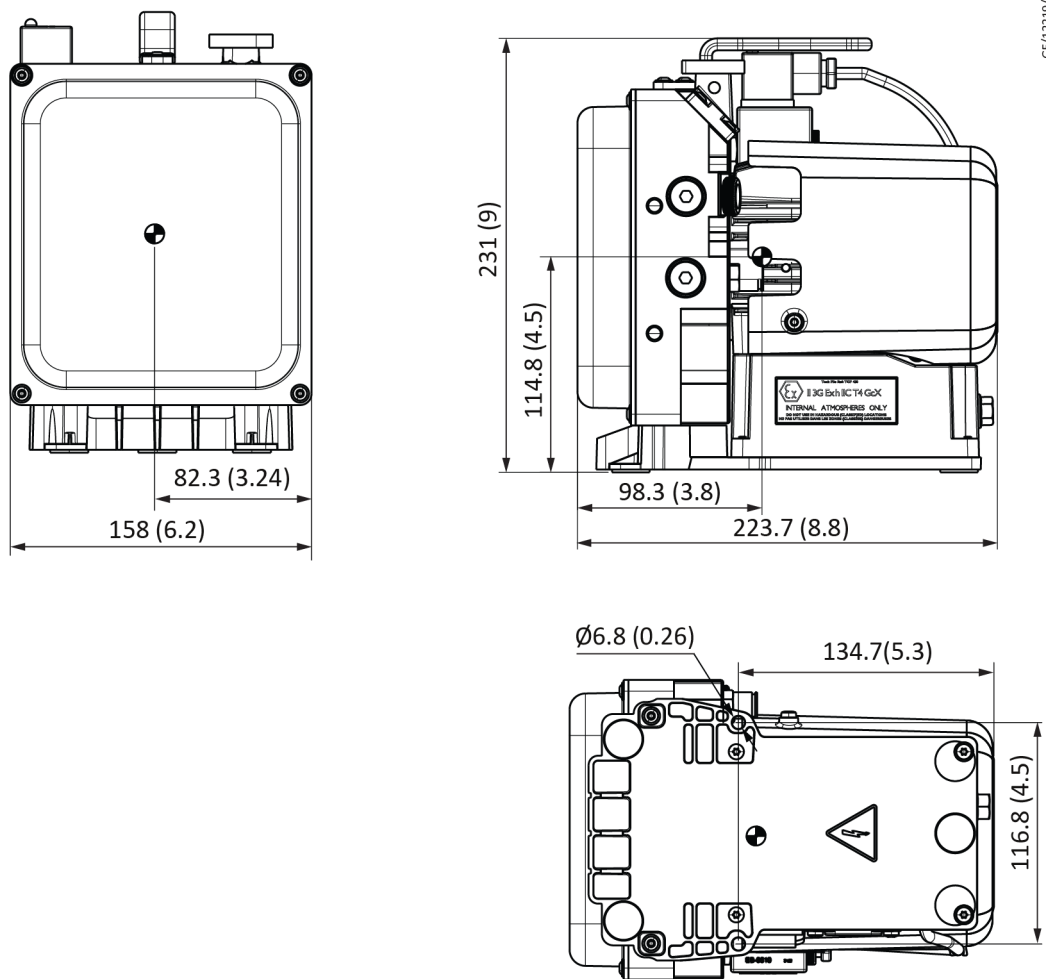

**Note:**

*All dimensions given are in mm (inch). External dimensions are the same for all variants.*

### 4.3 Unpack and inspect

1. Remove all packing materials and remove the pump from its packing-box by handle (tested according to IEC 61010-1 to 40 kg).
2. Remove the protective covers from the inlet and outlet-ports and inspect the pump. If the pump is damaged, notify the supplier and the carrier in writing within three days, state the Item Number of the pump together with the order number and the supplier's invoice number. Retain all the packing materials for inspection. Do not use the pump if it is damaged.

If the pump is not to be used immediately, replace the protective covers. Store the pump in the conditions, described in [Storage](#) on page 36. Refer to [Disposal](#) on page 37 for disposal of materials.

## 4.4 Position the pump



### WARNING: PUMP SAFETY

**Risk of injury or damage to the equipment. If the pump is to be used on the floor of a work area, position the power lead and the exhaust and inlet hoses with care. Make sure that personnel in the area are aware of any obstructions around the pump.**

Provide a firm, level platform for the pump. We recommend you to secure/screw the pump against falling in the event of a fault. Locate the pump so that the gas ballast control and the user controls are accessible.

If the pump will be located inside an enclosure, make sure that there is adequate ventilation at both ends of the pump, so that the ambient temperature around the pump does not exceed 40 °C. There must be a minimum space of 12 mm between the pump and the enclosure walls.

Pump could be operated in the horizontal (preferred) or vertical position. For vertical orientation use the accessories - adhesive rubber pads (refer to [Adhesive rubber pads](#) on page 48) or bracket (refer to [Bracket](#) on page 46). Extra adhesive rubber pads offered as a Spare.

In case of vertical running of the pump the bearing life time could be reduced by up to 50%.

### 4.4.1 Mechanical fixing

 **Note:**

*The pump can be secured by using the two holes located in the pockets of the pump base. We recommend you to use M6 bolts.*

## 4.5 Connect to the vacuum system



### WARNING: PUMP SAFETY

**Risk of injury or damage to the equipment. If pumping dangerous gases or vapours, connect the exhaust to a suitable treatment plant to prevent the discharge of dangerous gases and vapours to the surrounding atmosphere.**

**If the pump is operated with the exhaust line blocked, high pressure may be generated in the exhaust line pipework.**

Refer to [Figure: mXDS3/mXDS3s scroll pump](#) on page 11. Before connecting the pump to the vacuum system, remove the plastic cap from the inlet and exhaust, and make sure that the inlet strainer is fitted to the pump inlet port. Use appropriate DN 10/16 ISO-KF vacuum fittings for connection to the system.

Take note of the following information when connecting the pump to the vacuum system:

- To minimise noise and exhaust emissions, it is recommended that the pump is connected to an exhaust line or a silencer (refer to [Spares and accessories](#) on page 38).

- For optimum pumping speeds, make sure that the pipeline connected to the pump inlet is as short as possible and has a suitable internal diameter.
- Support the vacuum pipeline to prevent loading of the coupling joints.
- Maximum load on inlet 100N in any orientation.
- A pressure of 3.5 bar(g) may be generated in the exhaust pipework if the pump is operated with the exhaust line blocked. Connect the pump using appropriate pipework and fittings.
- If necessary, incorporate flexible bellows in the system pipelines to reduce the transmission of vibration and to prevent loading of the coupling joints. If using flexible bellows, make sure that bellows have a maximum pressure rating which is greater than the highest pressure that can be generated in the system. Manufacturer's bellows are recommended.
- Incorporate an inlet isolation valve in the pipeline from the vacuum system to the pump to isolate the vacuum system from the pump when it is switched off and prevent suck-back of process gases and debris into the vacuum system or buy scientific version of the product, which would do that automatically.
- Make sure that the sealing surfaces are clean and scratch-free.

We recommend you to use an exhaust extraction system suitable for use with all process gases that will be pumped. Make sure that the exhaust extraction system cannot become blocked or obstructed when the pump is operating.

A small amount of tip seal wear product may collect in the exhaust duct of the pump. The dust may be blown out with the initial burst of air after the pump has been vented. This is quite common and the amount of dust seen will reduce over time.

Leak test the system and seal any leaks found after pump installation.

## 4.6 Electrical installation

### 4.6.1 Fuses and circuit breakers



#### **WARNING: ELECTRICAL HAZARD**

**Risk of injury. Make sure that the electrical installation of the pump conforms to local and national safety requirements. The pump must be connected to a suitably fused and protected electrical supply with a suitable earth point. For recommended fuse ratings and cord sets refer to [Electrical data](#) on page 18.**



#### **CAUTION: ELECTRICAL CONNECTIONS**

**Risk of injury. Make sure that access to the pump electrical supply cable is not obstructed when locating the pump.**

**If using an earth leakage device, for example, a Residual Current Device (RCD), use a 30 mA (minimum) rated unit to avoid trip during start up.**

**The live conductor is fused inside the pump controller while the neutral conductor is not. An external RCD should be installed to guard against damage in the event of a short circuit between neutral and earth.**

For recommended protection ratings, refer to [Table: Recommended regional supply protection](#) in [Electrical data](#) on page 18.

## 4.6.2 Electrical supply connection

Use an IEC60320 connector (C13) and cable that meets local electrical standards when connecting to the pump. The pump must be earthed via the earth conductor of the IEC60320 connector. A list of cable specifications is available in [Electrical data](#) on page 18 of this manual.

We recommend you to fit a separate earth to the pump using a non-insulated braid or a separate insulated green or yellow conductor. The conductor must be a minimum of 16 AWG. Use the attached T20 screw and shake proof washer located on the side of the pump motor (refer to [Figure: mXDS3/mXDS3s scroll pump](#) on page 11) to secure the earth conductor to the pump.

## 4.6.3 Disconnect the pump from the electrical supply

Before removing the physical electrical supply connection to the pump, via the IEC60320 cable (C13), isolate the mains supply (refer to [Figure: mXDS3/mXDS3s scroll pump](#) on page 11).

## 4.6.4 Connect the pump to the electrical supply

### CAUTION: ELECTRICAL HAZARD



**Risk of damage. The pump will restart automatically when the electrical supply is restored after an interruption and when the pump cools after it has overheated. If automatic pump restart is not required, use electric control equipment that must be reset manually.**



## 5. Operation



### WARNING: OPERATION SAFETY

Risk of damage to the equipment. Make sure that the system design does not allow the exhaust pipeline to become blocked.



### CAUTION: CLEANING AREA

A fine dust may be emitted from the exhaust of the scroll pump during start up, particularly when the pump is new or if new tip seals are fitted.

### 5.1 Manual operation

The pump control functions of the user interface panel are detailed in [Figure: User interface panel](#) on page 25.

Figure 6 User interface panel

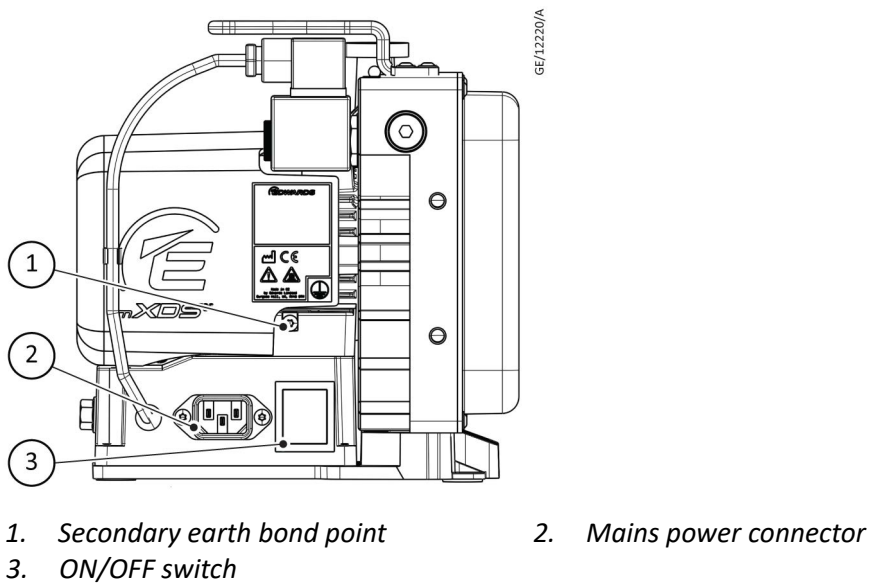

#### 5.1.1 Start and stop

Use the switch ([Figure: User interface panel](#) on page 25, items 3) to start and stop the pump.

**Table 10 Commissioning of the pump**

Operation	Select	Status	Section
Apply power	MAINS POWER	Set on-off switch to position 0 before applying the power otherwise the pump will run automatically.	<a href="#">Electrical supply connection</a> on page 24
Stop the pump	On-off switch to position 0	The pump will decelerate and stop running.	<a href="#">Start and stop</a> on page 25
Start the pump	On-off switch to position 1	The pump will accelerate up to full running speed.*	<a href="#">Start and stop</a> on page 25

\* The pump is set to 30 Hz rotational full speed (factory default).

## 5.2 Gas ballast control

To pump high vapour loads, gas ballast can be delivered into the pump to prevent condensation of the vapour carried by the pumped gases.

Air can be introduced to the low vacuum stages through the gas ballast control ([Figure: mXDS3/mXDS3s scroll pump](#) on page 11, item 3). Alternatively, an inert gas such as nitrogen can be supplied through a suitable external valve and by using the appropriate adaptor, available as an accessory. Refer to [Spares and accessories](#) on page 38.

### 5.2.1 Use of gas ballast control

The gas ballast control can be used to optimise the performance of the scroll pump for the application. The performance characteristics of the pump with gas ballast on are shown in [Performance characteristics](#) on page 15. The position of the gas ballast control can be changed when the pump is either off or operating.

 **Note:**

*If the pump is used on systems with very low flow or with high humidity then to help clear the vapours and tip seal dust from the pump, we recommend to use GB more frequently (approximately 0.5 hour every day).*

### 5.2.2 Gas ballast control plug

Use the gas ballast control plug (Item 3 on [Figure: mXDS3/mXDS3s scroll pump](#) on page 11) to introduce air into the final stage of the pump. Use of gas ballast will reduce the condensation of vapours in the pump. The condensates would contaminate the pump.

The gas ballast plug can be unscrewed by one revolution counter clockwise or removed completely. For gas ballast flow regulation see [Accessories](#) on page 39.

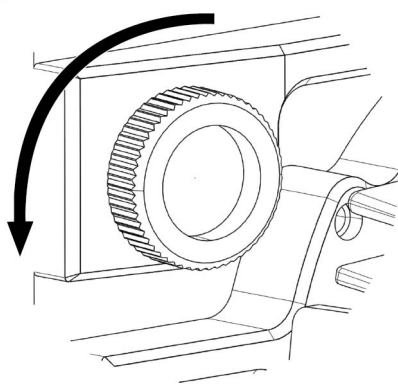
**Figure 7** Opening gas ballast plug

GE/12085/A

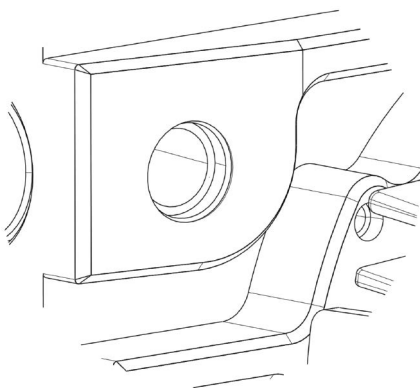
**Figure 8** Gas ballast plug removed

GE/12086/A

Refer to [Table: Performance characteristics](#).

### 5.3 Start-up procedure



#### **WARNING: ELECTRIC SHOCK**

Risk of injury or death by electric shock. Electrical cables with insulation rated for 70 °C maximum temperature can melt if they are in contact with the pump, potentially causing the pump to become live. Route and secure cables so that they do not touch the pump.

Use the procedure below to start up the pump:

1. Make sure that any vacuum system isolation valve is closed (if fitted).
2. With the mains supply to the pump isolated, connect a recommended lead to the electrical socket on the pump (refer to [Figure: mXDS3/mXDS3s scroll pump](#) on page 11).
3. Apply power.
4. Start the pump by switching on the power switch.
5. If vacuum isolation valve is fitted it will open automatically after approximately 10 second delay.

## 5.4 To achieve ultimate vacuum

In order to achieve the best possible vacuum, the pump should be operated with the gas ballast control turned off. However, if the pump, or elements of the vacuum system it is attached to, are new or have been newly fitted, some atmospheric moisture may be present. If atmospheric moisture is present, run the pump with gas ballast on for 20 minutes before turning gas ballast off. If moisture can remain, the performance of the pump will be impaired.

## 5.5 To pump condensable vapours

Open the gas ballast when there is a high proportion of condensable vapours in the process gases. This will assist the vapours to pass through the pump without condensing and keep the pump performance from degrading.

## 5.6 Shut down

Use the procedure below to shut down the pump:

1. If shutting the pump down prior to a period of storage, remove any residual process gases by running with nitrogen or another inert gas ballast.
2. Close any vacuum system isolation valves to prevent suck-back into the vacuum system (where fitted).
3. Stop the pump system using the On/Off switch in manual control mode.
4. Vent the pump system using the gas ballast control or the valve on the inlet.
5. Isolate the mains supply.

## 6. Maintenance

### 6.1 Maintenance safety



#### **WARNING: MAINTENANCE SAFETY**

Risk of damage to the equipment. Obey the safety instructions in this section and take note of appropriate precautions. Failure to observe these instructions may result in injury to people and damage to equipment.



#### **WARNING: ELECTRICAL CONNECTIONS**

Disconnect the pump and other components from the electrical supply to prevent accidental operation.

The pump may be contaminated with the process chemicals that have been pumped during operation. If so, make sure that the pump is decontaminated before maintenance and take correct precautions to protect people from the effects of dangerous substances if contamination has occurred.



#### **WARNING: HOT SURFACE**

Risk of injury. Do not touch or inhale the thermal breakdown products of fluorinated materials which may be present in the pump if the pump has been heated to 260 °C and above. Fluorinated materials are safe in normal use but can decompose into very dangerous substances (which may include fluorine and hydrofluoric acid) if heated to 260 °C and above. The pump may have overheated if it was misused or if it was in a fire. Safety Data Sheets for fluorinated materials used in the pump are available on request; contact us or the supplier.



#### **CAUTION: SAFETY INFORMATION**

External surfaces of the pump should be cleaned using a damp cloth. Care must be taken with solvent-based cleaning fluids as they may remove important information from the product labels.

The pump is designed to require little user maintenance. Observe the following guidelines when carrying out maintenance on the pump:

- Make sure the maintenance is done by a suitably trained and supervised technician. Obey local and national safety requirements.
- Make sure the maintenance technician is familiar with the safety procedures which relate to the products processed by the pumping system.
- Check that all the required parts are available and are of the correct type before starting work.
- Isolate the pump and other components from the electrical supply to prevent accidental operation.
- Allow the pump to cool for at least 3 hours before starting maintenance work.

## 6.2 Maintenance plan

More frequent maintenance may be required if the pump is used to pump aggressive gases or vapours, such as water, solvents, organic substances and acids, or if the pump is operated continuously at the higher end of its operating temperature or pressure.

*Table 11 Maintenance plan*

Operation	Frequency (months)	Section reference
Inspect and clean the inlet strainer	12	<i>Inspect and clean the inlet strainer</i> on page 30
Inspect and clean the external fan cover if required	12	<i>Clean the external fan cover</i> on page 30
Check the pump performance	12	<i>Check the pump performance</i> on page 31
Replace the tip-seals	When needed *	<i>Replace the tip-seals</i> on page 31
Replace the pump bearings	60	<i>Replace the pump bearings</i> on page 31
Replace capacitor	120	<i>Figure: Replace capacitor</i> on page 43
Electrical safety test	60	<i>Electrical safety check</i> on page 32
Exhaust silencer filter	When needed *	-

*\*But not more than 30 months*

## 6.3 Inspect and clean the inlet strainer

Whenever the pump is disconnected from the vacuum system, or on an annual basis, we recommend:

- Removing the inlet strainer from the pump inlet (refer to *Figure: mXDS3/mXDS3s scroll pump* on page 11) and remove any debris that may have accumulated.
- Inspecting the inlet strainer and if necessary, clean it with a cleaning solution suitable for the substances pumped. Refit the inlet strainer before reconnecting the pump to the vacuum system. Refer to *Connect to the vacuum system* on page 22.

## 6.4 Clean the external fan cover

If the fan cover is not kept clean, the air flow over the pump can be restricted and the pump may overheat.

To clean the external fan cover:

1. Switch off the pump and disconnect it from the electrical supply.
2. Use a dry cloth and a soft brush to remove dirt and deposits from the fan cover.

## 6.5 Check the pump performance

If the pump performance is within acceptable limits, or is performing satisfactorily, the tip-seal replacement can be delayed.

If operating a preventative maintenance plan, depending upon the particular regime, a tip-seal change can be carried out at this time irrespective of the pump performance.

## 6.6 Replace the tip-seals

This information is applicable to the replacement tip seal kit that must be fitted.

A tip-seal replacement should be carried out to maintain or restore the pumps performance. The frequency for replacing the pump tip-seals is determined by the following factors:

- The pump has reached a service interval. Refer to [Check the pump performance](#) on page 31 and [Replace the pump bearings](#) on page 31.
- The pump is no longer achieving the required performance.

If the pump is no longer achieving the required performance prior to a service interval being reached, we recommend you to follow the guide lines, refer to [The pump has failed to achieve the required performance](#) on page 33.

### Note:

*There may be a running-in period after fitting your new tip-seals. The performance should improve over a period of 24 to 48 hours. If the pump performance does not improve sufficiently after the running-in period, please contact us for advice.*

For information on how to replace the mXDS3 tip-seals refer to the mXDS3 replacement tip seal kit instruction manual P60102740. Also refer to Youtube video at <https://www.youtube.com/@EdwardsVacuum>.

## 6.7 Replace the pump bearings

Bearing wear cannot necessarily be detected under normal operating conditions. This service interval is a recommendation that a bearing replacement is required, this is especially useful if operating a preventative maintenance plan.

It is possible for an experienced technician, who is suitably trained, to perform maintenance and repair on pumps up to and including bearing replacement. We have developed an instructional video at <https://www.youtube.com/@EdwardsVacuum> that will enable an experienced technician to undertake this work. If required, we can also provide face to face training. Please contact us for more information or to purchase this training.

### Note:

*Failure to replace the pump bearings at this time may subsequently lead to damage of the pumping mechanism.*

*A tip-seal change and exhaust and ballast valve change should be carried out at the same time when performing a bearing replacement.*

## 6.8 Electrical safety check

Test the earth continuity and the insulation resistance of the pump system in accordance with local regulations for the periodic testing of electrical equipment.

The earth continuity should be less than  $0.1 \Omega$  and the DC insulation resistance greater than  $1.0 \text{ M}\Omega$ .

If the pump fails any of these tests, contact us or the supplier.



## 7. Fault finding

Whenever there is troubleshooting make sure the pump is disconnected from electricity, vacuum and technology.

### 7.1 The pump has failed to start or has stopped

- The electrical supply fuse has blown.
- The ambient temperature is too high.
- The cooling air supply is insufficient or is too hot.
- The process gas is too hot or the throughput is too high.
- The motor is faulty.
- If an issue occurred after the maintenance contact our service center.

### 7.2 The pump has failed to achieve the required performance

- Gas ballast may be open. To close gas ballast, tighten the gas ballast plug. Use this setting to achieve the best possible vacuum. If the pump has been used to pump condensable vapours or is to pump a large chamber that has been exposed to atmospheric air (water vapour), it may be necessary to run for at least an hour on gas ballast.
- If the electrical supply voltage is more than 10% below the lowest voltage specified on the user interface panel, the pump may operate but deliver a degraded vacuum performance.
- There is a leak in the system.
- Tip seals may need further run-in, typically 24 hours, with some requiring up to a maximum of 100 hours.
- The pressure measurement technique or gauge head is unsuitable or gives an incorrect indication of pressure.
- The vacuum fittings are dirty or damaged. Replace the fittings.
- The inlet strainer is blocked. Clean or replace the strainer.
- The connecting pipelines are too long or too small in diameter, conductance.
- There is high pressure or a blockage in the exhaust line.
- The pump contains traces of process vapours, Run 12 hours with gas ballast.
- The pump is outside the specified range of operating conditions.
- The tip seals need replacing.

### 7.3 The pump has poor ultimate vacuum

If the pump exhibits poor ultimate vacuum, refer to [Figure: Poor ultimate vacuum flow chart with inlet sealed](#) on page 34.

Figure 9 Poor ultimate vacuum flow chart with inlet sealed

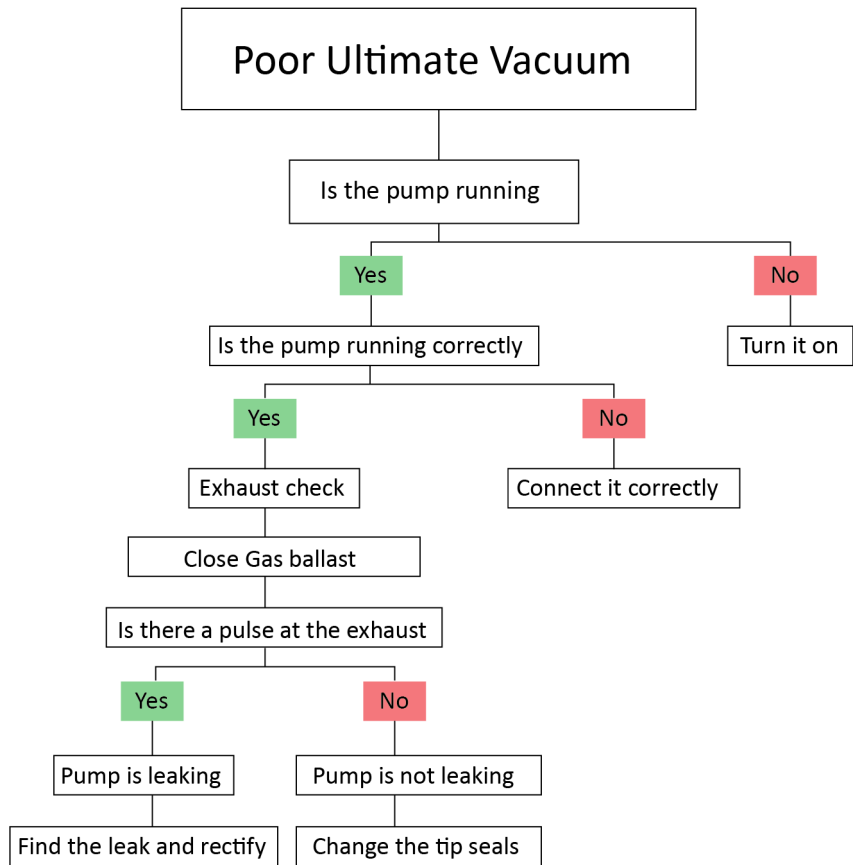

GE/12043/A

## 7.4 The pump is noisy

If the pump is noisy, refer to [Figure: Noisy pump flow chart with inlet sealed](#) on page 35.

- Check anti-rotation device for broken leg.
- Check if counter balance screw is not loose.

Figure 10 Anti-rotation device

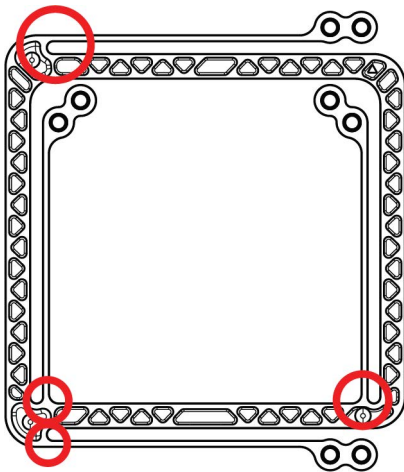

Check red circle marked area  
 Make sure there are no cranking damage

Figure 11 Noisy pump flow chart with inlet sealed

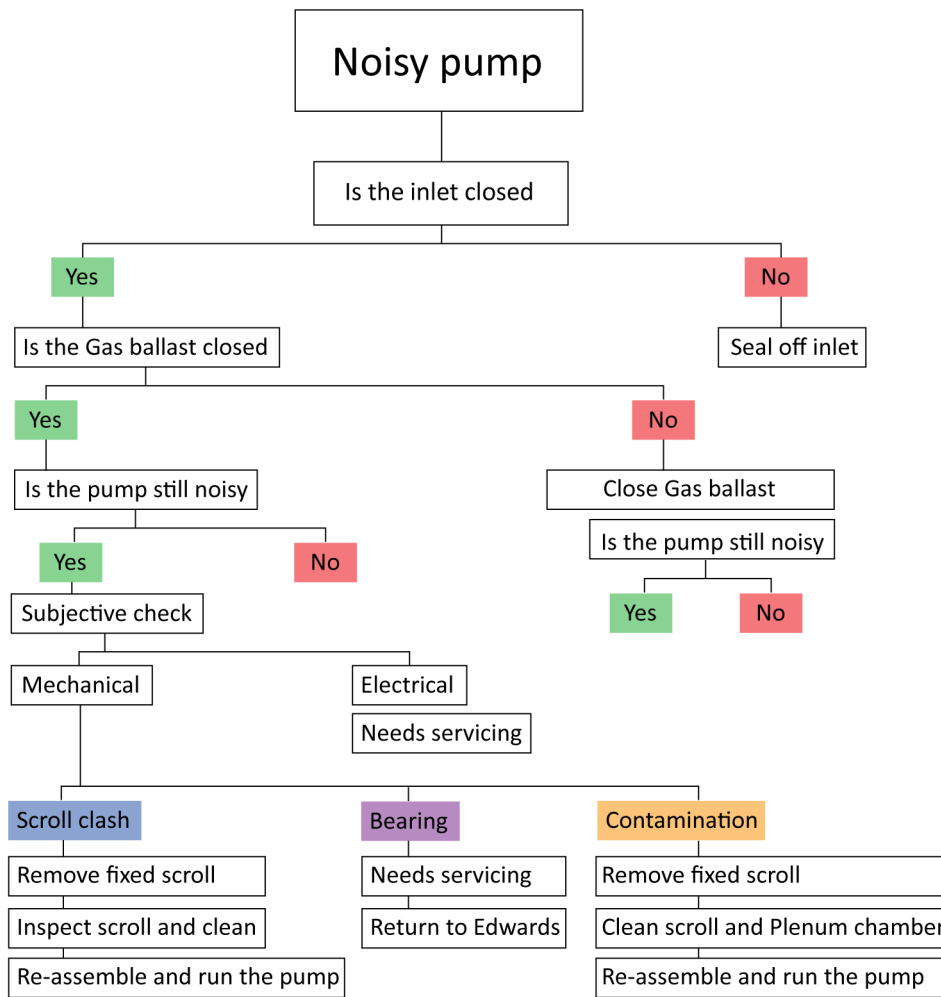

GE/13681/A

## 7.5 The pump surface temperature is high

- The ambient temperature is too high.
- The cooling air supply is insufficient or is too hot.
- The process gas is too hot or the maximum continuous operating pressure has been exceeded.

## 8. Storage

Use the following procedure to store the pump:

1. Shut down the pump as described in *Shut down* on page 28.
2. Disconnect the pump from the electrical supply.
3. Place and secure protective covers over the inlet and outlet ports.
4. Store the pump in cool, dry conditions until required for use. When required, prepare and install the pump as described in *Installation* on page 20.

### 8.1 Pump storage for less than 2 years

- If the storage period is less than 1 year, the pump can be used in a standard way.
- If the storage period is between 1 and 2 years, we recommend to do the following steps every half of the year:
  - Run the pump at ultimate pressure for 10 hours.
  - Run for another 14 hours with opened GB valve to clean and dry the pump.

### 8.2 Pump storage for more than 2 years

If the storage period is longer than 2 years without operating, we recommend you to service the pump.

## 9. Disposal

Dispose of the pump and any components from it safely in accordance with all local and national safety and environmental requirements.

Particular care must be taken with components which have been contaminated with dangerous process substances.

Do not incinerate fluoroelastomer seals and O-rings.

## 10. Spares and accessories

### 10.1 Spares



#### CAUTION: SUPPLIED SPARES

Risk of damage to equipment. If you use spares that are not supplied by us, it will decrease the reliability and performance of the pump. This will also invalidate the product warranty.

#### 10.1.1 Tip-seal kit

Refer to youtube video at <https://www.youtube.com/@EdwardsVacuum>. Used to maintain or restore the performance of the pump.

*Table 12 Tip-seal kit*

Product description	Ordering information
Tip-seal kit	GK7440001

#### 10.1.2 Bearing replacement kit

Replace the bearings when its service life ends. This is approximately after 32000 hours.

When the bearings are necessary to replace, we recommend:

- Always replace tip seal and other parts from tip seal kit when replacing bearings.
- Use all supplied parts from the bearing kit.
- Always follow instructions supplied with special tooling.
- Watch our maintenance video for better understanding of the procedure.

*Table 13 Bearing replacement kit*

Product description	Ordering information
Bearing replacement kit	GK7440002

#### 10.1.3 Gas ballast and exhaust kit

Used when gas ballast or exhaust pad deteriorates or gets damaged by harsh operation and sealing properties are reduced. Contains spring, valve pad, gas ballast insert and additional o-rings.

*Table 14 Gas ballast and exhaust kit*

Product description	Ordering information
Gas ballast and exhaust kit	GK7440003

#### 10.1.4 DN 16 ISO KF inlet adaptor

In case original inlet will be damaged or broken this is spare part for replacement.

Table 15 DN 16 ISO KF Inlet adaptor

Product description	Ordering information
DN 16 ISO KF Inlet adaptor	GK7440004

## 10.2 Accessories

Figure 12 The mXDS3/mXDS3s accessories

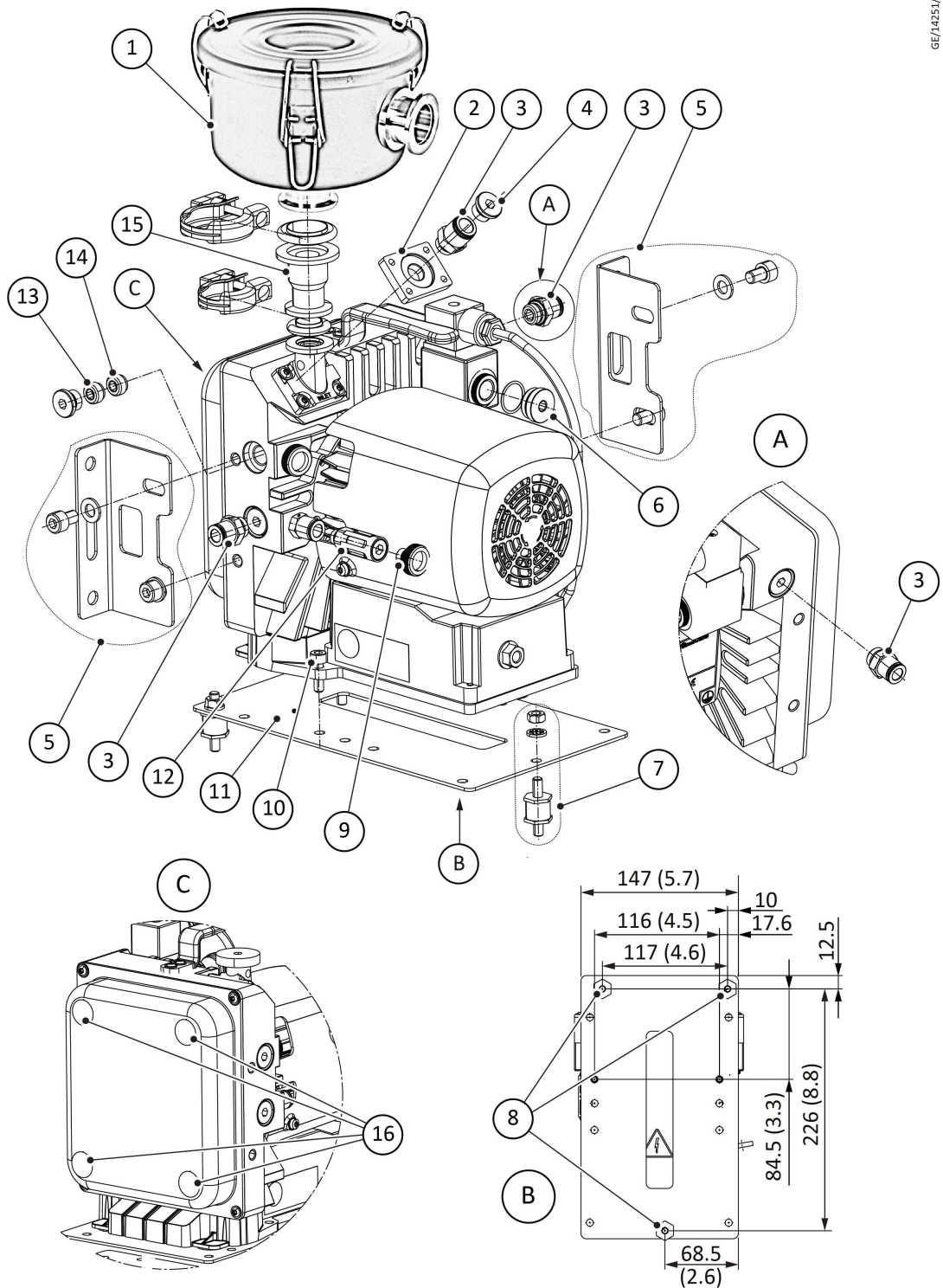

GE/14251/A

- |  |   |
|--|---|
| <ul style="list-style-type: none"> <li>A. Detailed view</li> <li>C. Detailed view</li> <li>1. Inlet filter</li> <li>3. 1/4" push in fitting side mounting option</li> <li>5. Bracket</li> <li>7. Vibration Isolator</li> <li>9. Gas ballast plug</li> <li>11. Base Mounting plate</li> <li>13. Gas ballast fine restrictor</li> <li>15. Reduction DN 16/25 ISO-KF</li> </ul> | <ul style="list-style-type: none"> <li>B. Dimension drawing</li> <li>2. The inlet 1/4" BSP adaptor</li> <li>4. Blanking plug</li> <li>6. Solenoid valve plug</li> <li>8. Vibration Isolator mounting position</li> <li>10. Screw cap head M6x20 DIN 912</li> <li>12. Silencer</li> <li>14. Gas ballast coarse restrictor</li> <li>16. Adhesive rubber pads</li> </ul> |
|--|---|

### 10.2.1 Inlet valve

Isolating pump from technology from pump inlet above.

*Table 16 Inlet valve*

Product description	Ordering information
Inlet valve 100 - 120 V	A74402920
Inlet valve 200 – 240 V	A74402921



Figure 13 Inlet valve

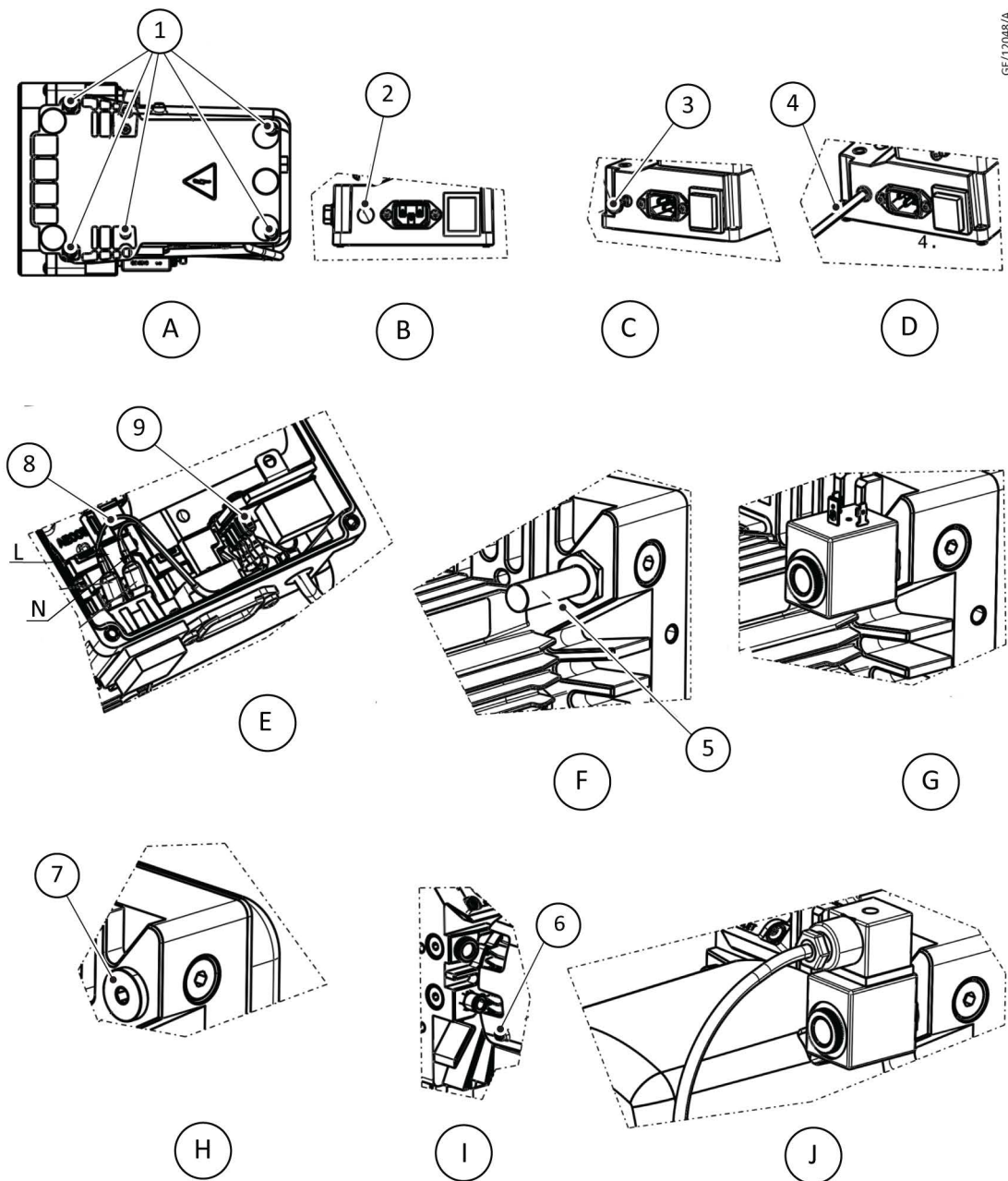

GE/12048/A

- |   |                                       |
|---|---------------------------------------|
| 1. Remove 6 screws  | 2. Remove plug                        |
| 3. Install supplied grommet                                   | 4. Install wire                       |
| 5. Valve body   | 6. Remove screw                       |
| 7. Remove plug  | 8. Plug wire delay relay power source |
| 9. Plug wires to 1 <sup>st</sup> and 2 <sup>nd</sup> position |                                       |

1. Remove 6 screws from base plate.
2. Remove plastic plug in hole diameter 10 mm.
3. Attach supplied grommet.
4. Push through the leads from valve connector and connect it to the delay relay.
5. Remove M20 plug.
6. Screw in the valve body – use Hex key 16.

7. Fit in the valve coil and secure by plastic nut.
8. Attach the valve connector with flying leads.
9. Perform electrical safety test.

### 10.2.2 Delay relay

PCB placed into terminal box of the motor providing 10 second delay for opening the inlet valve.

*Table 17 Delay relay*

Product description	Ordering information
Delay relay	A74402922

*Table 18 Replace capacitor*

Part number	Capacitor	Variant
G74401607	Capacitor with 25 $\mu$ F	100 - 115V
G74401608	Capacitor with 8 $\mu$ F	200 - 230V

**Figure 14** Replace capacitor

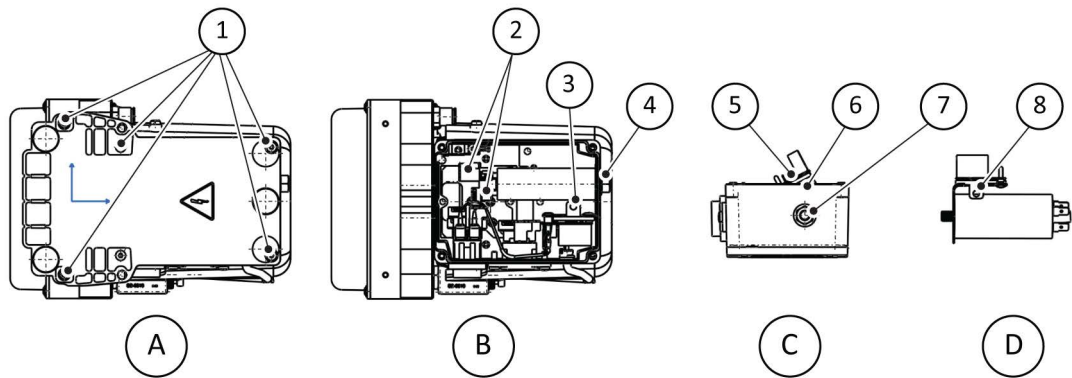

1. Remove 6 screws
2. Disconnect wires
3. Turn
4. Untight nut
5. Disconnect wires
6. Turn
7. Remove nut
8. Remove these parts from terminal box, replace capacitor

1. Remove 6 screw from base plate.
2. Disconnect wires leading from motor to capacitor.
3. Loosen M8 nut and turn bracket by 90°.
4. Fit in the thermal pad (cutouts on holes with PCB supports).
5. Snap in the delay relay on PCB supports.
6. Connect switch and delay relay by wire A74401079 (delay relay power source wire).

**Figure 15** Pin connection of delay relay

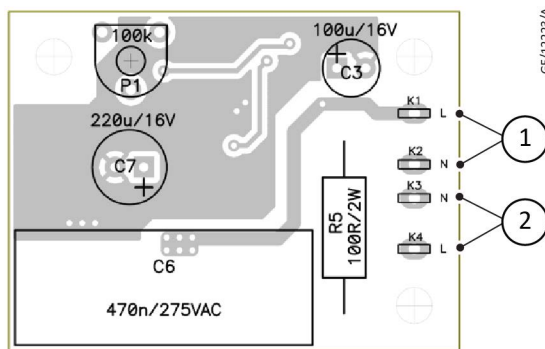

1. Input - from electrical connector
2. Output - to valve
7. Turn the bracket by 90° back and tighten the M8 nut by 2 Nm.
8. Put back base plate and secure by 6 original screws.
9. Perform electrical safety test.

### 10.2.3 Gas ballast or exhaust push-in fitting

Fitting with 1/8" BSP for hose connection of outer diameter 8 mm.

**Table 19 Gas ballast or exhaust push-in fitting**

Product description	Ordering information
Gas ballast or exhaust push-in fitting	A74402925

### 10.2.4 Gas ballast fine restrictor

Exchangeable valve seat with reduced diameter size and spare O-ring.

Gas ballast coarse restrictor is included in standard delivery.

**Table 20 Gas ballast fine restrictor**

Product description	Ordering information
Gas ballast fine restrictor	A74402926

Installation instructions:

1. Remove 1/4" BSP plug by allen key.
2. Unscrew original gas ballast restrictor by the same key.
3. Screw in gas ballast fine restrictor and 1/4" BSP plug back in.
4. Check leak tightness.

#### Step by step for exchange GB insert 1/4" BSP

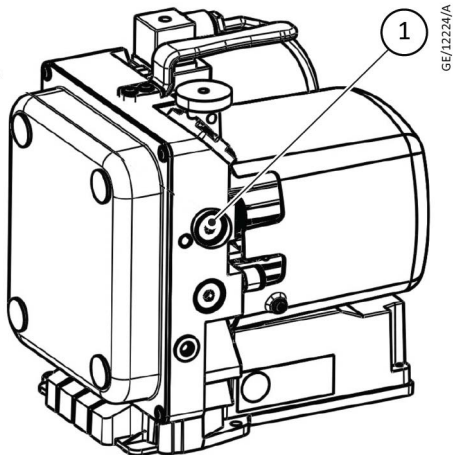

1. Locating

**Detail location of GB insert 1/4" BSP**

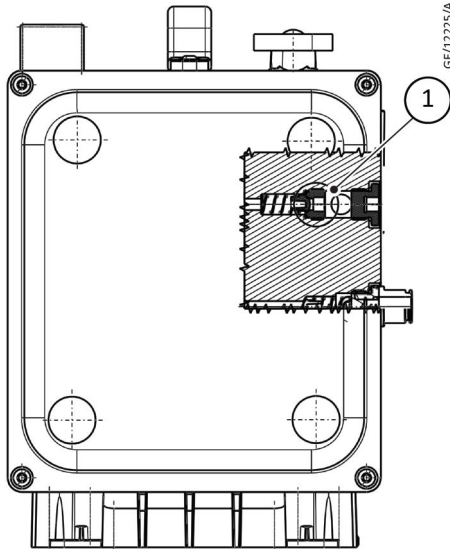

1. A26002004 GB insert 1/4" BSP

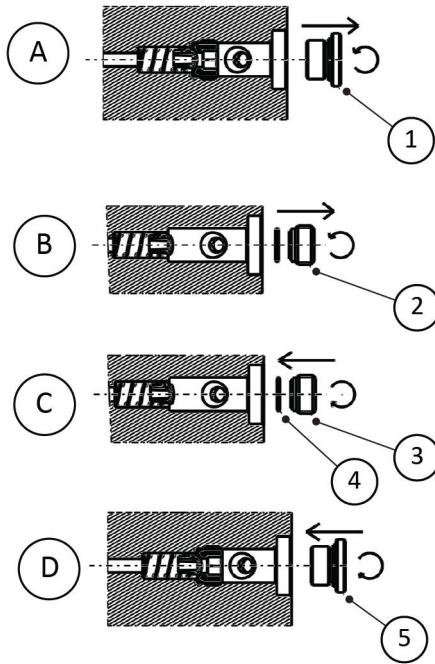

A. *Unbolt plug 1/4*

C. *Screw new GB inset 1/4 and tightening 2.5 Nm*

1. *Use Hex key size 6 mm*

3. *Use Hex key size 6 mm*

5. *Use Hex key size 6 mm*

B. *Unbolt GB insert 1/4 and exchange it*

D. *Screw plug 1/4 and tightening 2.5 Nm*

2. *Use Hex key size 6 mm*

4. *Take extreme care to alignment and fit of O-ring to bottom surface*

**10.2.5 Inlet push in fitting 1/4"**

Fitting of 1/4" BSP to fit the hose of outer diameter 10 mm.

**Table 21 Inlet push in fitting 1/4"**

Product description	Ordering information
Inlet push in fitting 1/4"	A74402927

### 10.2.6 Inlet 1/4" BSP adaptor

In case of requirement to attach the hose to inlet the DN 16 ISO KF adaptor can be removed and adaptor with 1/4" BSP thread can be mounted by the same set of screws that secured original adaptor in place. It is recommended to use it with push fit adaptor (refer to [Inlet push in fitting 1/4"](#) on page 45) with OD10 mm to keep the pump performance.

**Table 22 Inlet 1/4" BSP adaptor**

Product description	Ordering information
Inlet 1/4" BSP adaptor	A74402928

### 10.2.7 Base mounting plate

This base mounting plate is used for fixing the pump to the floor or a frame or a T-station. Can be used with vibration isolators for either 3 point or 4 point mounting to reduce vibration transmission.

**Table 23 Base mounting plate**

Product description	Ordering information
Base mounting plate	A74402929

### 10.2.8 Bracket

Mounting bracket enabling the pump to be secured in vertical orientation. Can be used with vibration isolators to reduce vibration transmission. See [Vibration isolator kit](#) on page 47.

**Table 24 Bracket**

Product description	Ordering information
Bracket	A74402930

**Figure 16** mXDS3 mounting

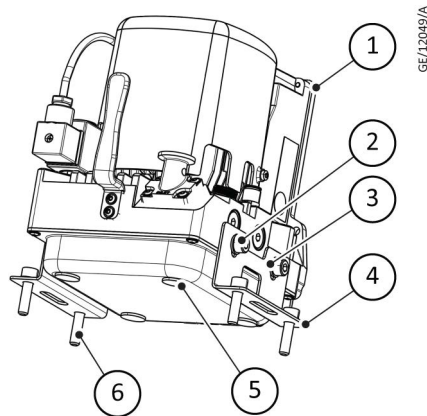

- |  |   |
|--|---|
| <p>1. mXDS3 edwards scientific</p> <p>3. Washer norm M8 SS</p> <p>5. Adhesive rubber</p> | <p>2. SKT* cap HD screw M8 x 12</p> <p>4. Mounting bracket miniscroll</p> <p>6. M8 x 30 soc HD cap screw SS</p> |
|--|---|

\* DIN 912 Stainless steel

### 10.2.9 Exhaust silencer/gas ballast filter

A silencer is available for the pump. Refer to [Connect to the vacuum system](#) on page 22 for guidance on its use.

**Table 25** Exhaust silencer/gas ballast filter

Product description	Ordering information
Exhaust silencer/gas ballast filter 1/8" BSP	A74402931

### 10.2.10 Vibration isolator kit

Fit vibration isolators to the pump to reduce the transmitted vibration from the pump to a structure, such as a frame or a system. Four washers and four nuts included.

**Table 26** Vibration isolator kit

Product description	Ordering information
Vibration isolator kit (pack of 4)	A74402932

### 10.2.11 Inlet filter

The inlet dust filter can be connected inline between the pump inlet and your chamber outlet connection to prevent dust from migrating into your system. The filter is supplied ready to use with a 5 µm element.

Inlet filter flange size is NW25 therefore reduction to NW16 is required to mount it to pump inlet.

**Table 27** Inlet filter

Product description	Ordering information
Inlet filter DN25-ISO-KF	140125T

### 10.2.12 Reduction DN 16/25 ISO-KF

*Table 28 Reduction DN 16/25 ISO-KF*

Product description	Ordering information
Reduction DN16/25 ISO-KF - stainless steel	C10514447
Reduction DN16/25 ISO-KF - aluminium	C10514437

### 10.2.13 Adhesive rubber pads

Set of additional adhesive rubber pads used as feet attached to pump base plate or front cover.

*Table 29 Adhesive rubber pads*

Product description	Ordering information
Adhesive rubber pads (pack of 4)	A74402933

### 10.2.14 Electrical cables

Refer to [Table: Electrical cables](#). The following electrical cables are available as accessories and should be used to connect the pump to the electrical supply.

*Table 30 Electrical cables*

Product description	Ordering information
Lead Assembly, 10 Amax, C13, UK	A50505000
Lead Assembly, 10 Amax, C13, Europe	A50506000
Lead Assembly, 10 Amax, C13, USA	A50507000
Lead Assembly, 10 Amax, C13, No Plug	A50508000



## 11. Service

### 11.1 Return the equipment or components for service

Before you send your equipment to us for service or for any other reason, you must complete a Declaration of Contamination Form. The form tells us if any substances found in the equipment are hazardous, which is important for the safety of our employees and all other people involved in the service of your equipment. The hazard information also lets us select the correct procedures to service your equipment.

If you are returning equipment note the following:

- If the equipment is configured to suit the application, make a record of the configuration before returning it. All replacement equipment will be supplied with default factory settings.
- Do not return equipment with accessories fitted. Remove all accessories and retain them for future use.
- Return in original packaging if possible to prevent damage during transport.

Download the latest documents from [edwardsvacuum.com/HSForms/](http://edwardsvacuum.com/HSForms/), follow the procedure in HS1, fill in the electronic HS2 form, print it, sign it, and return the signed copy to us.



#### **NOTICE:**

**If we do not receive a completed form, your equipment cannot be serviced.**



## EU Declaration of Conformity

This declaration of conformity is issued under the sole responsibility of the manufacturer:

**Edwards Ltd**

Innovation Drive  
Burgess Hill  
West Sussex  
RH15 9TW  
UK

**Documentation Officer**

Jana Sigmunda 300  
Lutín , 78349  
Czech Republic  
T: +42(0) 580 582 728  
[documentation@edwardsvacuum.com](mailto:documentation@edwardsvacuum.com)

The product specified and listed below

- |                            |           |
|----------------------------|-----------|
| • mXDS3 230V 1ph 50/60 Hz  | A74401903 |
| • mXDS3 200V 1ph 50/60 Hz  | A74401904 |
| • mXDS3 115V 1ph 50/60 Hz  | A74401906 |
| • mXDS3 100V 1ph 50/60 Hz  | A74401907 |
| • mXDS3s 230V 1ph 50/60 Hz | A74402903 |
| • mXDS3s 200V 1ph 50/60 Hz | A74402904 |
| • mXDS3s 115V 1ph 50/60 Hz | A74402906 |
| • mXDS3s 100V 1ph 50/60 Hz | A74402907 |

Is in conformity with the relevant requirements of European CE legislation:

- |            |   |
|------------|---|
| 2006/42/EC | Machinery directive<br><i>Note: The safety objectives of the Low Voltage Directive 2014/35/EU were complied with in accordance with Annex 1 No. 1.5.1 of this directive.</i>                              |
| 2014/34/EU | ATEX directive on use in potentially explosive atmospheres<br>⊕ II 3G Ex h IIC T4 Gc X<br>Only the internal pumping mechanism is classified as ATEX category 3, external parts and motor are not in scope |
| 2014/30/EU | Electromagnetic compatibility (EMC) directive<br>Class A Emissions, Industrial Immunity   |
| 2011/65/EU | Restriction of certain hazardous substances (RoHS) directive<br>as amended by Delegated Directive (EU) 2015/863   |

Based on the relevant requirements of harmonised standards:

- |                         |  |
|-------------------------|--|
| EN 1012-2:1996 +A1:2009 | Compressors and vacuum pumps. Safety requirements. Vacuum pumps  |
| EN ISO 80079-36:2016    | Explosive atmospheres – Part 36: Non-electrical equipment for explosive atmospheres. Basic method and requirements   |
| EN ISO 80079-37:2016    | Explosive atmospheres - Part 37: Non-electrical equipment for explosive atmospheres - Non-electrical type of protection constructional safety "c", control of ignition sources "b", liquid immersion "k" |
| EN 61326-1:2013         | Electrical equipment for measurement, control and laboratory use. EMC requirements. General requirements   |

This declaration, based on the requirements of the listed Directives and EN ISO/IEC 17050-1, covers all product serial numbers from this date on: 2023-06-02

You must retain the signed legal declaration for future reference  
This declaration becomes invalid if modifications are made to the product without prior agreement.

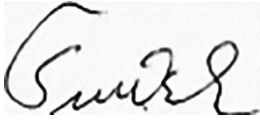

*Petr Šmerek – Engineering Manager  
Scientific Vacuum Division, Lutín*



*Jan Večeřa – General Manager  
Lutín, CZ*



## Declaration of Conformity

**Edwards Ltd**

Innovation Drive  
Burgess Hill  
West Sussex  
RH15 9TW  
UK

**Documentation Officer**

[documentation@edwardsvacuum.com](mailto:documentation@edwardsvacuum.com)

This declaration of conformity is issued under the sole responsibility of the manufacturer.

- |                            |           |
|----------------------------|-----------|
| • mXDS3 230V 1ph 50/60 Hz  | A74401903 |
| • mXDS3 200V 1ph 50/60 Hz  | A74401904 |
| • mXDS3 115V 1ph 50/60 Hz  | A74401906 |
| • mXDS3 100V 1ph 50/60 Hz  | A74401907 |
| • mXDS3s 230V 1ph 50/60 Hz | A74402903 |
| • mXDS3s 200V 1ph 50/60 Hz | A74402904 |
| • mXDS3s 115V 1ph 50/60 Hz | A74402906 |
| • mXDS3s 100V 1ph 50/60 Hz | A74402907 |

The object of the declaration described above is in conformity with relevant statutory requirements:

**Supply of Machinery (Safety) Regulations 2008**

*The objectives of the Electrical Equipment (Safety) Regulations 2016 are governed by Annex 1 1.5.1 of this regulation.*

**Equipment and Protective Systems Intended for use in Potentially Explosive Atmospheres Regulations 2016**

⊕ II 3G Ex h IIC T4 Gc X

Only the internal pumping mechanism is classified as ATEX category 3, external parts and motor are not in scope.

**Electromagnetic Compatibility Regulations 2016**

Class A Emissions, Industrial Immunity

**Restriction of the Use of Certain Hazardous Substances in Electrical and Electronic Equipment Regulations 2012**

Relevant designated standards or technical specifications are as follows:

- |                         |   |
|-------------------------|---|
| EN 1012-2:1996 +A1:2009 | Compressors and vacuum pumps. Safety requirements. Vacuum pumps   |
| EN ISO 80079-36:2016    | Explosive atmospheres – Part 36: Non-electrical equipment for explosive atmospheres. Basic method and requirements  |
| EN ISO 80079-37:2016    | Explosive atmospheres - Part 37: Non-electrical equipment for explosive atmospheres -- Non-electrical type of protection constructional safety "c", control of ignition sources "b", liquid immersion "k" |
| EN 61326-1:2013         | Electrical equipment for measurement, control and laboratory use. EMC requirements. General requirements  |

This declaration, based on the requirements of the listed Statutory Instruments and EN ISO/IEC 17050-1, covers all product serial numbers from this date on: 2023-06-02

You must retain the signed legal declaration for future reference  
This declaration becomes invalid if modifications are made to the product without prior agreement.

**Signed for and on behalf of Edwards Ltd**

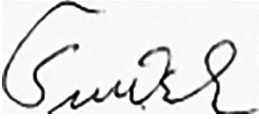

*Petr Šmerek – Engineering Manager  
Scientific Vacuum Division, Lutín*



*Jan Večeřa – General Manager  
Lutín, CZ*

## ADDITIONAL LEGISLATION AND COMPLIANCE INFORMATION

EMC (EU, UK): Class A Industrial equipment

Caution: This equipment is not intended for use in residential environments and may not provide adequate protection to radio reception in such environments.

RoHS (EU, UK): Material Exemption Information

This product is compliant with no Exemptions

REACH (EU, UK)

This product is a complex article which is not designed for intentional substance release. To the best of our knowledge the materials used comply with the requirements of REACH. The product manual provides information and instruction to ensure the safe storage, use, maintenance and disposal of the product including any substance based requirements.

Article 33.1 Declaration (EU, UK)

This product does not knowingly or intentionally contain Candidate List Substances of Very High Concern above 0.1%ww by article as clarified under the 2015 European Court of Justice ruling in case C-106/14.

### Additional Applicable Requirements

The product is in scope for and complies with the requirements of the following:

2012/19/EU	Directive on waste electrical and electronic equipment (WEEE)
Product is certified to CSA-C22.2 No.61010-1-12	Safety requirements for electrical equipment for measurement, control and laboratory use – Part 1: General requirements CU 72300923
Product is certified to UL61010-1 3 <sup>rd</sup> Edition	Safety requirements for electrical equipment for measurement, control and laboratory use – Part 1: General requirements CU 72300923
IEC 61010-1:2010/AMD1:2016	Safety requirements for electrical equipment for measurement, control and laboratory use Part1: General requirements
EN 60529:1991 + A2:2013	Specification for degree of protection provided by enclosures (IP code) – IP code 20

### 材料成分声明

### China Material Content Declaration



表示该有害物质在该部件的所有均质材料中的含量低于 GB/T 26572 标准规定的限量要求。

Indicates that the hazardous substance contained in all of the homogeneous materials for this part is below the limit requirement in GB/T 26572.

